

# OPERATOR'S MANUAL

# 6694X-XXX

INCLUDING: SERVICE KITS, TROUBLESHOOTING, PARTS LIST AND DISASSEMBLY AND REASSEMBLY.

RELEASED: 11-27-90  
REVISED: 1-27-23  
(REV. T)

## TWO-BALL STYLE LOWER PUMP ENDS 66941-XXX (400 Series Stainless Steel) 66942-XXX (300 Series Stainless Steel)

Also covers 637211-XX3 service kits.



**READ THIS MANUAL CAREFULLY BEFORE INSTALLING, OPERATING OR SERVICING THIS EQUIPMENT.**

It is the responsibility of the employer to place this information in the hands of the operator. Keep for future reference.

### SERVICE KITS

- Use only genuine ARO® replacement parts to assure compatible pressure rating and longest service life.
- **637211-XX3** for general repair of 6694X-XXX lower pump ends.

### GENERAL DESCRIPTION

**⚠ WARNING DO NOT EXCEED MAXIMUM OPERATING PRESSURE AS INDICATED ON PUMP MODEL PLATE.**

**⚠ WARNING REFER TO GENERAL INFORMATION SHEET FOR ADDITIONAL SAFETY PRECAUTIONS AND IMPORTANT INFORMATION.**

- This manual only covers the lower pump section. It is one of four documents which support an ARO pump. Replacement copies of these forms are available upon request.
- 650XXX-X Pump Model Operator's Manual
- General Information - Air / Hydraulically Operated Piston Pumps
- Lower Pump End Operator's Manual
- Air / Hydraulic Motor Operator's Manual
- The two-ball design provides better priming of the lower foot valve. The double acting feature is standard in all ARO industrial pumps. Material is delivered to the pump discharge outlet on both the up and down stroke.

### MAINTENANCE

The air / hydraulic motor is completely separate from the lower pump end. This helps to keep the motor from being contaminated by the material being pumped. Periodically, flush the entire pump system with a solvent that is compatible with the material being pumped.

Keep the solvent cup filled with this compatible solvent. This will keep the material from drying on the piston rod, which could drag through the packings, ruin them and eventually scour the piston rod.

Provide a clean work surface to protect sensitive internal moving parts from contamination from dirt and foreign matter during disassembly and reassembly.

Before reassembly, lubricate parts as required. When assembling "O" rings or parts adjacent to "O" rings, exercise care to prevent damage to "O" rings and "O" ring groove surface.

### LOWER PUMP END DESCRIPTION CHART

6694X - X X X

#### Pump Material

- 1 - 400 series stainless steel
- 2 - 300 series stainless steel

#### Packing Material

- 5 - Mineral filled PTFE / Leather staggered (upper)  
Mineral filled PTFE (lower)
- C - UHMW-PE (upper and lower)
- F - UHMW-PE/Leather staggered (upper)  
UHMW-PE (lower)
- K - Carbon Graphite filled PTFE with Nitrile Energizer (upper and lower)
- L - Mineral filled PTFE (upper and lower)
- N - Leather (upper)  
UHMW-PE (lower)
- P - UHMW-PE / Mineral filled PTFE staggered (upper)  
UHMW-PE (lower)
- R - Mineral filled PTFE / UHMW-PE staggered (upper)  
Mineral filled PTFE (lower)

#### Spring Arrangement (Service kit spring designation)

- 3 - No spring (3)
- 6 - Wave spring (6)
- C - No spring with alternate seat material (3)
- D - Wave spring with alternate seat material (6)

#### Plunger Type

- 3 - Hardened stainless steel with hard chrome plating (threaded)
- 6 - Stainless steel with hard chrome plating (threaded)
- D - Hardened stainless steel with hard chrome plating (large motors)
- F - Stainless steel with hard chrome plating (large motors)

#### Service Kit Selection

EXAMPLE: Lower Pump End # 66941-CDF  
Service Kit # 637211-C63

6694X - X X X  
637211 -   3  
Packing  Spring

- ARO® is a registered trademark of Ingersoll-Rand •
- Loctite® and 242® are registered trademarks of Henkel Loctite Corporation •
- Primer T™ is a trademark of Henkel Loctite Corporation •

## PARTS LIST / 6694X-XXX

Item	Description (size)	(Qty)	Part No.	[Mtl]
1	Solvent Cup	(1)	66730	[SS]
6	Pump Body	(1)	79166	[SS]
✓ 8	"O" Ring (3/32" x 3-9/16" OD) (models 6694X-KXX)	(2)	93333	[B]
	(models 6694X-CXX, -FXX, -LXX, -NXX, -PXX, -RXX, -5XX)	(2)	92619	[T]
9	Suction Tube (models 66941-XXX)	(1)	92599-1	[SH]
	(models 66942-XXX)	(1)	79164	[SS]
10	Tie Rod	(3)	79156	[SS]
12	Nut (1" - 14)	(3)	79184	[SS]
15	Foot Valve Body	(1)	92613	[SS]
17	Ball (1.5000" OD) (models 66941-XXX)	(1)	Y16-148	[SH]
	(models 66942-XXX)	(1)	79155	[SS]
20	Pin (5/16" OD x 3-7/16")	(1)	79157	[SS]
22	Ball Seat (models 66941-X3X, 66941-X6X)	(1)	92608	[SH]
	(models 66942-X3X, 66942-X6X)	(1)	77431	[SS]
	(models 6694X-XCX, 6694X-XDX)	(1)	95769	[TC]
✓ 23	Gasket	(1)	92609	[SS]
24	Seat Retainer	(1)	92607	[SS]
26	Plunger (models 6694X-XXD)	(1)	67204	[PSH]
	(models 6694X-XXF)	(1)	67205	[PSS]
27	Ball (1.0000" OD) (models 66941-XXX)	(1)	Y16-132	[SH]
	(models 66942-XXX)	(1)	90948	[SS]
28	Ball Seat (models 66941-X3X, 66941-X6X)	(1)	92610	[SH]
	(models 66942-X3X, 66942-X6X)	(1)	77430	[SS]
	(models 6694X-XCX, 6694X-XDX)	(1)	95770	[TC]

### MATERIAL CODE

[B] = Nitrile	[SS] = Stainless Steel
[Ny] = Nylon	[T] = PTFE
[PSH] = Hard Chrome Plated Hard Stainless Steel	[TC] = Tungsten Carbide
[PSS] = Hard Chrome Plated Stainless Steel	[UH] = UHMW-PE
[SH] = Hard Stainless Steel	[L] = Leather

### LOWER PUMP DISASSEMBLY

- Unscrew three (12) nuts from (10) tie rods.
- Remove (15) foot valve body from (10) tie rods and (9) suction tube. **NOTE:** Use of a soft face mallet might be helpful to accomplish this step.
- Note the position of (20) pin and (17) ball from (15) foot valve body.
- Unscrew (24) seat retainer and remove (22) ball seat, (23) gasket and (8) "O" ring.
- Pull (9) suction tube and (26) plunger from (6) pump body.
- Push (26) plunger assembly out lower end of (9) suction tube.
- Unscrew (36) seat body and remove (29) gasket, (27) ball and (28) ball seat from (26) plunger. **NOTE:** (36) seat body has two 0.250" dia. x 0.250" deep holes. Use a spanner wrench (ARO tool 637404-B is available) to loosen.
- Remove (40) retaining ring from (36) seat body.
- Remove (8) "O" ring from (6) pump body.
- Unscrew (1) solvent cup from (6) pump body. **NOTE:** (1) solvent cup has six 3/8" dia. x 3/8" deep holes. Use a rod or spanner wrench to loosen.
- Remove (45) washer, (44) wave spring, (53) male washer, (51 and 52) packings and (50) female washer from (1) solvent cup.

Item	Description (size)	(Qty)	Part No.	[Mtl]
✓ 29	Gasket	(1)	92612	[SS]
36	Seat Body	(1)	93234	[SS]
40	Retaining Ring	(1)	93225	[SS]
✓ 44	Wave Spring (models 6694X-X6X, -XDX)	(1)	79175	[SH]
✓ 45	Washer	(1)	93041	[Ny]
✓ 50	Washer (models 6694X-CXX, -FXX, -NXX, -PXX)	(1)	93756-4	[UH]
	(models 6694X-LXX, -RXX, -5XX)	(1)	93756-5	[T]
✓ 51	"V" Packing (models 6694X-FXX, -PXX)	(2)	93683-4	[UH]
	(models 6694X-CXX)	(4)	93683-4	[UH]
	(models 6694X-RXX, -5XX)	(2)	93683-5	[T]
	(models 6694X-LXX)	(4)	93683-5	[T]
✓ 52	"V" Packing (models 6694X-RXX)	(2)	93683-4	[UH]
	(models 6694X-PXX)	(2)	93683-5	[T]
	(models 6694X-FXX, -5XX)	(2)	93683-1	[L]
✓ 53	Male Packing Washer (models 6694X-CXX, -FXX, -LXX, -NXX, -PXX, -RXX, -5XX)	(1)	92602	[SS]
✓ 71	"W" Packing (models 6694X-CXX, -PXX, -FXX, -NXX)	(1)	93758-4	[UH]
	(models 6694X-LXX, -RXX, -5XX)	(1)	93758-5	[T]
✓ 72	Wiper (models 6694X-CXX, -FXX, -NXX, -PXX)	(1)	93757-4	[UH]
	(models 6694X-LXX, -RXX, -5XX)	(1)	93757-5	[T]
✓ 75	Packing (models 6694X-KXX only)	(1)	93568-1	[T]
✓ 76	Packing (models 6694X-KXX only)	(1)	93567-1	[T]
✓	Items included in Service Kit		637211-XX3	

### LOWER PUMP REASSEMBLY

All threads are right hand.

Apply lubricant to all rubber parts before assembling (it is not necessary to lubricate UHMW-PE and PTFE packings).

**NOTE: All threads are to be cleaned before reassembly. The cleaning of threads is a benefit to help insure the overall reassembly process. Please note the use of the following materials: Loctite® Primer T™ with Loctite 242® Threadlocker and Loctite Nickel Anti-Seize.**

All threaded parts are stainless steel and care should be taken on threaded connections.

Apply Loctite Nickel Anti-Seize to threads as indicated (figure 1, page 3) during assembly.

Apply ARO Wet-Sol "Plus" to threads as indicated (figure 1, page 3) during assembly.

Apply Primer T with Loctite 242 Threadlocker to threads as indicated (figure 1, page 3) during assembly. Follow these instructions to apply materials to threads.

- Clean parts with solvent and allow to dry.
- Apply Primer T to mating threaded parts and allow 3 to 5 minutes to dry at 72° F.
- Apply Loctite 242 Threadlocker to mating threaded parts being assembled.
- Assemble parts within 3 minutes of applying Threadlocker.
- Tighten per "Torque Requirements", (see page 3).
- Curing times: Fixed in 5 minutes and full cure in 2 hours. **NOTE:** If Primer T is not used, the cure time will be effected as follows: fixed in 20 minutes and full cure in 24 hours.

(continued on page 4)

**PARTS LIST / 6694X-XXX**

**Models 66941-XXD  
Models 66942-XXF**

**Models 6694X-C6X, F6X, -L6X, N6X, -P6X, -R6X, 56X  
6694X-CDX, FDX, -LDX, NDX -PDX, -RDX, 5DX**

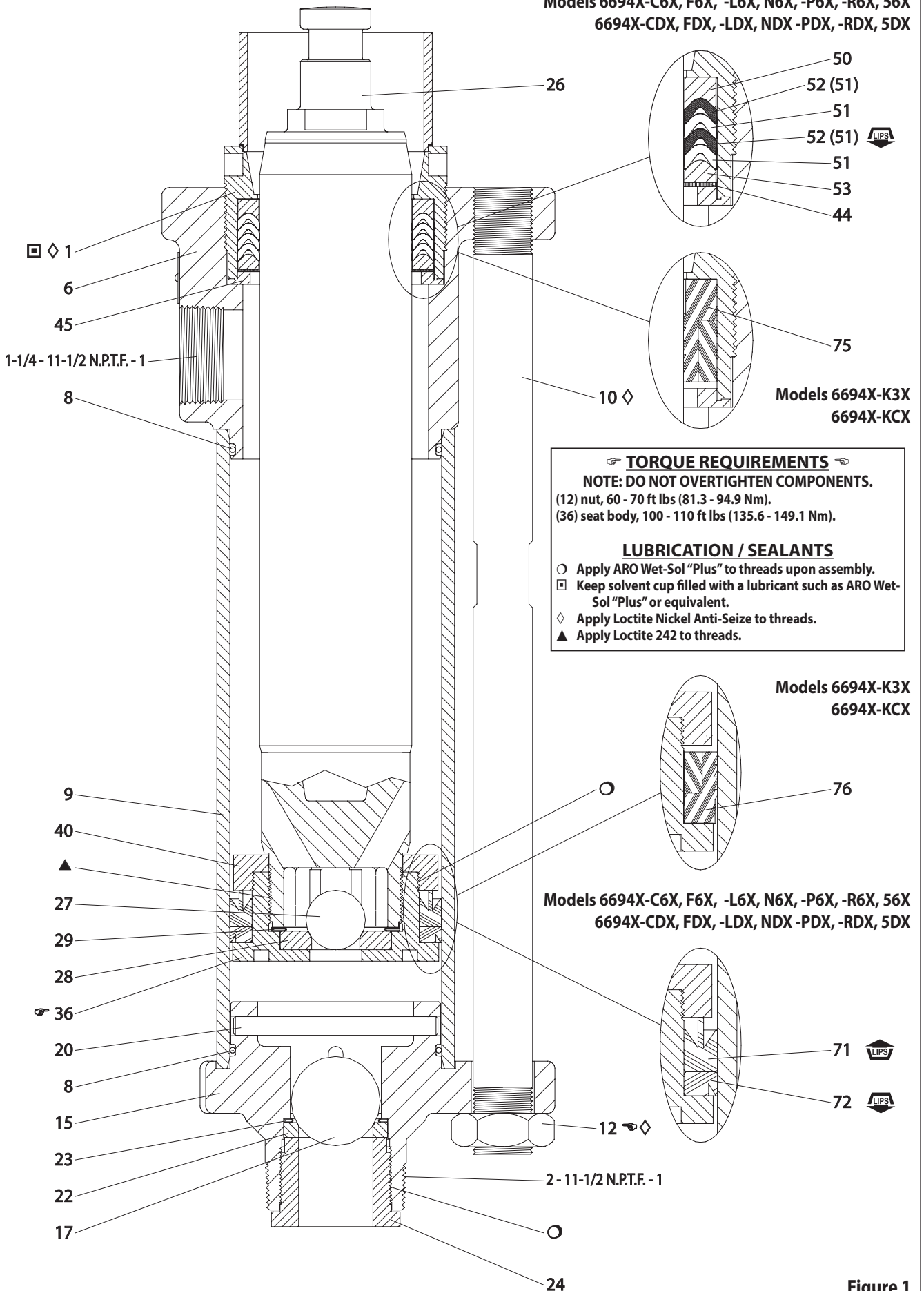

**TORQUE REQUIREMENTS**  
**NOTE: DO NOT OVERTIGHTEN COMPONENTS.**  
 (12) nut, 60 - 70 ft lbs (81.3 - 94.9 Nm).  
 (36) seat body, 100 - 110 ft lbs (135.6 - 149.1 Nm).

**LUBRICATION / SEALANTS**

- Apply ARO Wet-Sol "Plus" to threads upon assembly.
- ◻ Keep solvent cup filled with a lubricant such as ARO Wet-Sol "Plus" or equivalent.
- ◇ Apply Loctite Nickel Anti-Seize to threads.
- ▲ Apply Loctite 242 to threads.

**Models 6694X-K3X  
6694X-KCX**

**Models 6694X-C6X, F6X, -L6X, N6X, -P6X, -R6X, 56X  
6694X-CDX, FDX, -LDX, NDX -PDX, -RDX, 5DX**

**Figure 1**

1. Install (50) female washer, upper packings, (53) male washer and (44) wave spring in (1) solvent cup.

**NOTE:** The wave spring is split and the wave where the split occurs should be next to the metal back-up washer.

2. Install (45) washer in (6) pump body and screw (1) solvent cup into (6) pump body (do not tighten).
3. Put (8) "O" ring on (6) pump body.
4. Apply lubricant to (26) plunger and upper packing. Carefully slide the above assembled parts, (1) solvent cup and (6) pump body with internal packing arrangement over the top of (26) plunger. Retain (6) pump body in bench vise and tighten (1) solvent cup. Carefully lay assembled parts aside for future assembly.
5. Put lower packing on (36) seat body.
6. Install (40) retaining ring on (36) seat body and lay aside for future assembly.
7. Put other (8) "O" ring onto (15) foot valve body.
8. Place (20) pin, (17) ball, (23) gasket and (22) ball seat (bevel up) into (15) foot valve body and screw in (24) seat retainer.

Position the (20) pin in the (15) foot valve body as described in the following paragraph.

- A. Bottom holes (closest to ball) should be used for light viscosity materials.
- B. Center holes for medium viscosity materials (as assembled from factory).
- C. Top holes for heavy viscosity materials.

**NOTE:** These assembled parts are to be laid aside for future assembly.

9. Place assembled (26) plunger, (6) pump body and (1) solvent cup, with packing upright, in a bench vise, retained by the flats on (26) plunger at (1) solvent cup end. **NOTE:** Plunger to be vertical in vise.
10. Put (27) ball in ball guide end of (26) plunger. Place (29) gasket on sealing surface above ball guide. Apply Loctite 242 to threads of (26) plunger. Place (28) ball seat (bevel up) into (36) seat body and assemble to (26) plunger. **NOTE:** Tighten (36) seat body to 100 - 110 ft lbs (135.6 - 149.1 Nm). **NOTE:** ARO tool 637404-B is available to assemble body and plunger.
11. Lip on (72) wiper is to be rolled inward using a flat surface with no sharp edges (such as a steel dowel rod) to prevent damage of packing plus easier assembly. This process may have to be repeated several times to assure small enough diameter has been achieved to insure proper assembly.

12. Apply lubricant to inside of (9) suction tube and carefully slide over the assembled (71) packing and (72) wiper and onto the (6) pump body.

**NOTE:** Once the suction tube has cleared (71) packing and (72) wiper, a rubber mallet can be used to drive (9) suction tube into place.

13. Apply lubricant to (8) "O" ring and assemble to (15) foot valve body, then assemble (15) foot valve body into (9) suction tube. A rubber mallet can be used in this application.
14. Align the three holes in (15) foot valve body with the three threaded holes in (6) pump body. Screw (10) tie rods into (6) pump body. **NOTE:** Rods are to be flush with the top side of (6) pump body. Using the flats provided on (10) tie rod, secure the entire assembly with (12) nuts. **NOTE:** Tighten (12) nuts to 60 - 70 ft lbs (81.3 - 94.9 Nm). **NOTE:** Do not tighten each nut completely at once but draw them equally together and then tighten.

---

## TROUBLESHOOTING

---

### No material at outlet (pump continually cycles).

- Check material supply. Disconnect or shut off the air supply and replenish the material. Reconnect.

### Material on one stroke only (fast downstroke).

- The (17) lower ball may not be seating in the (22) seat (see lower pump disassembly). Remove the ball from the seat, clean and inspect the ball and seat area. If the ball or seat is damaged, replace.

### Material on one stroke only (fast upstroke).

- Check for worn or damaged packings and seals. Replace the packings and seals as necessary.

### Material leakage out of the solvent cup or material appears on the pump plunger rod.

- Relieve the pressure in the pump and tighten the solvent cup until leakage discontinues. If this procedure does not aid in stopping the leakage problem, the upper packings may be worn (see lower pump disassembly). Replace the packings as necessary.