

OPERATOR'S MANUAL 650311-X AND 650312-X

INCLUDING: SPECIFICATIONS, SERVICE KITS, GENERAL INFORMATION, TROUBLESHOOTING.

INCLUDE MANUALS: 1875CXXXXXX Lower Pump End (pn 97999-1583), 67316 Air Motor (pn 97999-1045) and S-632 General Information Manual (pn 97999-624)

RELEASED: 10-10-12

REVISED: 8-4-17

(REV: E)

2" AIR MOTOR
2:1 RATIO
3" STROKE

650311-X AND 650312-X TWO BALL PUMP SERIES with Cycle Sensor Stainless Steel



READ THIS MANUAL CAREFULLY BEFORE INSTALLING, OPERATING OR SERVICING THIS EQUIPMENT.

It is the responsibility of the employer to place this information in the hands of the operator. Keep for future reference.

SPECIFICATIONS

Model Series (refer to option chart) 650311-X and 650312-X
Pump Type Air Operated, Two Ball, Stainless Steel Pump
Ratio 2:1
Air Motor 67400
Motor Repair Kit 637377
Motor Diameter 2" (5.08 cm)
Stroke 3" (7.62 cm)
Air Inlet (female) 1/4 - 18 NPTF - 1

Lower Pump End Series

650311 1875C11SS22
650311-4 1875C11FF22
650311-5 1875C11SS29
650311-6 1875C11FF29
650311-7 1875C11VF29
650311-8 1875C11VS22
650311-9 1875C11VF2E
650312 1875C51SS22
650312-4 1875C51FF22

Lower End repair kit

650311-4/-6, 650312-4 K1875C11FF00
650311/650311-5, 650312 K1875C11SS00
650311-8 K1875C11VS00
650311-7/-9 K1875C11VF00

Ball and Seat Service Kit

..... 637011
Material Inlet (female) 1-1/4 - 11-1/2 NPSM
Material Outlet (female) 3/4 - 14 NPTF - 1

Weight see chart

PUMP PERFORMANCE

Air Inlet Pressure Range 30 - 150 psig (2.1 - 10.3 bar)
Fluid Pressure Range 60 - 343 psig (4.1 - 23.6 bar)
Maximum Rec'd Cycles / Minute 120
Flow Rate @ 120 Cycles / Minute 4.26 gpm (16.121 lpm)
Displacement / Cycle @ 100 psig 8.2 in.³ (134.4 cc)
Cycles Per Gallon 28
Noise Level 80 dB(A)Ⓞ

Accessories Available

61113 Wall Mount Bracket
66073-1 AirLine Connection Kit

Ⓞ The pump sound pressure level has been updated to an Equivalent Continuous Sound Level (LAeq) to meet the intent of ANSI S1.13-1971, CAGI-PNEUROP S5.1 using four microphone locations.

PUMP DATA

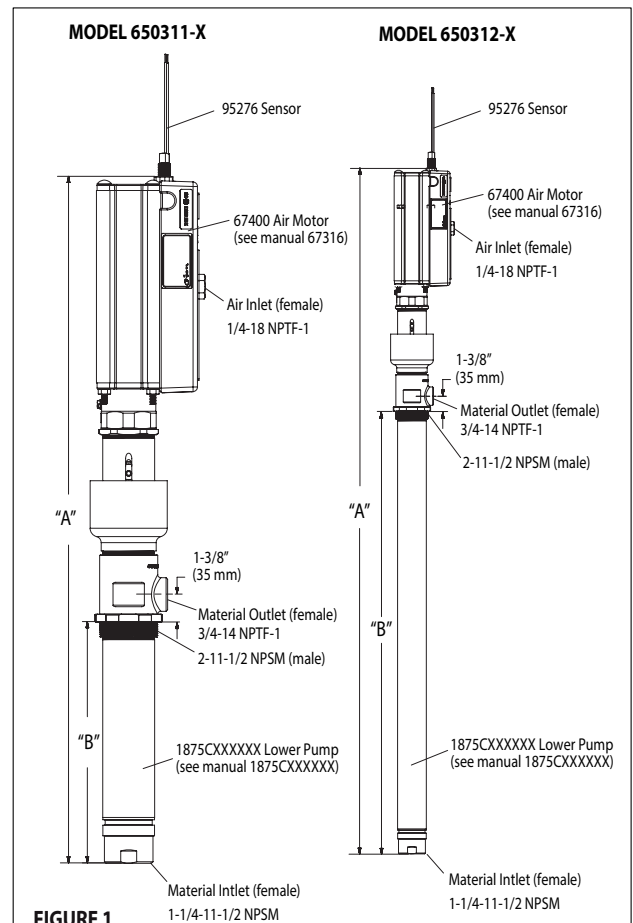

FIGURE 1

NOTE: Dimension are shown in inches and (mm), supplied for reference only and are typically rounded upto the nearest 1/16 inch.

MODEL	"A" (mm)	"B" (mm)	WEIGHT (kg)
650311-X	28.093" (714)	9.875" (251)	23 (10.4)
650312-X	51.437" (1306)	33.219" (846)	41 (18.6)

IMPORTANT

This is one of four documents which support the pump. Replacement copies of these forms are available upon request.

- 650311-X and 650312-X** Model Operator's Manual (pn 97999-1588)
- S-632** General Information - Industrial Piston Pumps (pn 97999-624)
- 1875CXXXXXX** Lower Pump End Operator's Manual (pn 97999-1583)
- 67316** Air Motor Operator's Manual (pn 97999-1045)

INGERSOLL RAND COMPANY LTD
209 NORTH MAIN STREET - BRYAN, OHIO 43506

☎ (800) 495-0276 • FAX (800) 892-6276
arozone.com

© 2017

CCN 48395826

ARO

IR Ingersoll Rand

PUMP OPTION DESCRIPTION CHART

65031-X-X

Container Suitability
Description

CONTAINER SUITABILITY

- 1 - Universal (stub)
- 2 - 55 Gallon

DESCRIPTION

- PTFE packing (upper and lower)/ Plain Rod and Tube
- 4 - UHMW-PE packing(upper and lower) / Plain Rod and Tube
- 5 - PTFE packing (upper and lower) / Ceramic Coated Rod and Tube
- 6 - UHMW-PE packing(upper and lower) / Ceramic Coated Rod and Tube
- 7 - Viton packing(upper)/UHMW-PE packing (lower)/ Ceramic Coated Rod and Tube
- 8 - Viton packing(upper)/PTFE packing (lower)/ Plain Rod and Tube
- 9 - Viton packing(upper)/UHMW-PE packing (lower)/ Plain Rod and Tube

GENERAL DESCRIPTION

Model 65031X-X Series two-ball, double acting pumps are intended to be used primarily for oil transfer and delivery systems. It is best to use this pump with low -- medium viscosity fluids. It uses Stainless steel and other materials which make it compatible with most petroleum based lubrication products. The two-ball design provides better priming of the lower foot valve. Double acting pumps will deliver material on both the up and down stroke.

NOTE: If this pump was purchased separately (not part of a system), consult your sales representative for compatible dispensing accessories which will best match the application. All accessories must be able to withstand the maximum pressure developed by the pump.

⚠️ WARNING HAZARDOUS PRESSURE. Do not exceed maximum operating pressure of 343 psig (23.6 bar) at 150 psig (10.3 bar) inlet hydraulic pressure.

Pump Ratio X = Maximum Pump Inlet Pressure to Pump Motor Fluid Pressure

Pump ratio is an expression of the relationship between the pump motor area and the lower pump end area. EXAMPLE: When 150 psig (10.3 bar) inlet pressure is supplied to the motor of a 4:1 ratio pump, it will develop a maximum of 600 psig (41.4 bar) fluid pressure (at no flow) - as the fluid control is opened, the flow rate will increase as the motor cycle rate increases to keep up with the demand.

⚠️ WARNING Refer to general information sheet for additional safety precautions and important information.

NOTICE: Thermal expansion can occur when the fluid in the material lines is exposed to elevated temperatures. Example: Material lines located in a non-insulated roof area can warm due to sunlight. Install a pressure relief valve in the pumping system.

Replacement warning label (pn 94520) is available upon request.

TROUBLE SHOOTING

Pump problems can occur in either the Air Motor Section or the Lower Pump End Section. Use these basic guidelines to help determine which section is affected. Be sure to eliminate any possible non-pump problems before suspecting pump malfunction.

Pump will not cycle.

- No pressure to the motor. See motor manual.
- Damaged motor. Service motor.

No material at the outlet (pump continually cycles).

- Check the material supply, disconnect or shut off the air supply and replenish the material, reconnect.

Material on one stroke only (fast downstroke).

- The lower check may not be seating in the foot valve (see lower pump disassembly). Remove the check from the foot valve, clean and inspect the valve seat area. If check or foot valve are damaged, replace.

Material on one stroke only (fast upstroke).

- The middle packings may be worn (see lower pump disassembly). Replace the seals as necessary.

PUMP CONNECTION - UPPER / LOWER

NOTE: All threads are right hand.

1. Loosen (90606) lock nut and unscrew the entire pump from the air motor. This will expose (94445) adapter (see figure 2).

2. Unscrew (94445) adapter to remove pump assembly from the air motor.
3. Remove the (Y15-21) cotter pin and (94048) clevis pin to remove (94445) adapter.

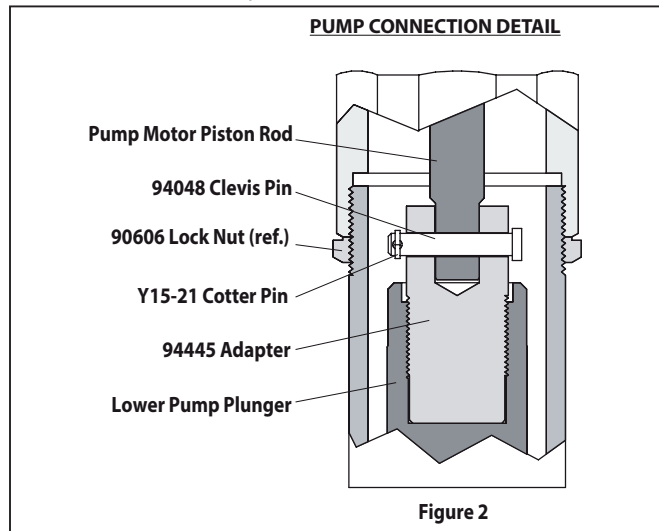

Figure 2

REASSEMBLY

1. Assemble (94445) adapter to the air motor rod, aligning the through holes.
2. Assemble (94048) clevis pin through hole, securing adapter.
3. Assemble (Y15-21) cotter pin through the hole in the clevis pin.
4. Apply Loctite® 242 to threads of (94445) adapter and screw (94445) adapter into (90615-X) plunger.
5. Screw the lower pump assembly to the air motor.
6. Screw (90606) lock nut against the air motor base and tighten to 50 - 60 ft. lbs (67.8 - 81.3 Nm).

OPERATION - SENSOR

Maximum Operating Voltage - 200VDC.

Switching Current -0.5 Amps.

Once the kit is installed in the pump, it may be interfaced with a control device in the following ways:

As a SOURCING switch (see figure 3) for use with PLC's.

As a SINKING switch (see figure 4) for use with PLC's.

As a closed contact switch (see figure 5) for use with meters.

