

# OPERATOR'S MANUAL & SALES AND ENGINEERING DATA

INCLUDING: OPERATION, INSTALLATION & MAINTENANCE

INCLUDE MANUAL: AF046X-XX AIR MOTOR (pn97999-1466) & S-632 GENERAL INFORMATION (pn97999-624)

RELEASED: 9-29-15

REVISED: 12-18-15  
(REV. C)

**4-1/4" AIR MOTOR  
75:1 RATIO  
0 - 7500 PSI RANGE**

## AF0475LXXXXXX-XX-X BASIC GREASE PUMP



**READ THIS MANUAL CAREFULLY BEFORE INSTALLING,  
OPERATING OR SERVICING THIS EQUIPMENT.**

It is the responsibility of the employer to place this information in the hands of the operator. Keep for future reference.

### SERVICE KITS

- Use only genuine ARO® replacement parts to assure compatible pressure rating and longest service life.
- **637512** for Lower Kit.
- **637489** for air motor service only.

### SPECIFICATIONS

**Model Series** . . . . . AF0475LXXXXXX-XX-X  
**Type** . . . . . Air Operated Grease Pump  
**Ratio** . . . . . 75:1  
**Air Motor Diameter** . . . . . 4-1/4" (10.8 cm)  
**Stroke** . . . . . 6" (15.2 cm)  
**Air Inlet** . . . . . 1/2 - 14 NPTF  
**Material Outlet (female)** . . . . . 1/2 - 14 NPTF  
**Dimensional Data** . . . . . see chart

### PERFORMANCE

**Air Inlet Pressure Range** . . . . . 0 - 100 psig (0 - 6.9 bar)  
**Fluid Pressure Range** . . . . . 0 - 7500 psig (0 - 517 bar)  
**Max Rec'd Speed (Continuous)** . . . . . 75 cycles/min  
**Flowrate @ 75 cycles per minute** . . . . . 5.5 lbs/min (~0.73 gpm)  
**Displacement Per Cycle** . . . . . 2.25 in<sup>3</sup> (36.87 cc)  
**Mount Accessories** . . . . . 4148 Bung Adapter

### GENERAL DESCRIPTION

These ARO pumps are designed to handle heavy greases and oils.

### IMPORTANT

**This is one of three documents which support the pump. Replacement copies of these forms are available upon request.**

- AF0475LXXXXXX-XX-X** Model Operator's Manual (pn97999-1759).
- AF046X-XX** Air Motor Operator's Manual (pn97999-1466).
- S-632** General Information - Industrial Piston Pumps (pn97999-624).

### AF0475LXXXXXX-XX-X

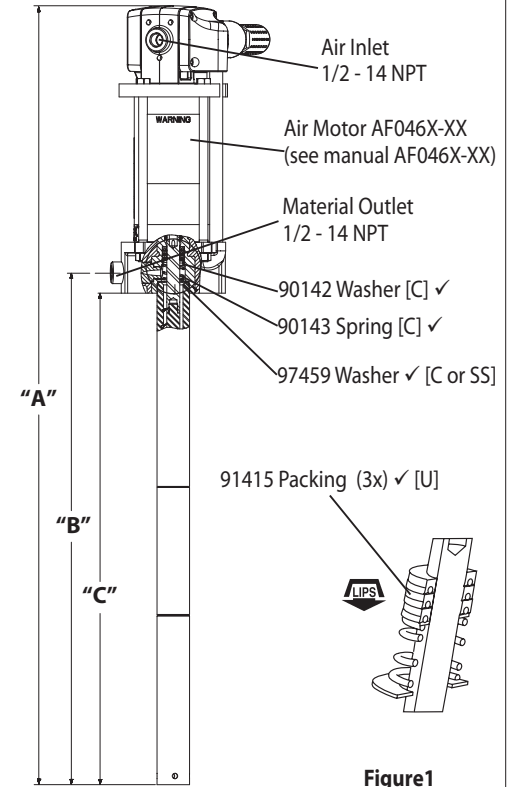

**Figure 1**

NOTE: Dimensions are shown in inches supplied for reference only.

MODELS	"A"	"B"	"C"	"Container Suitability"
<b>AF0475L4</b>	42.894"	29.507"	28.331"	16 Gallon (120 lbs)
<b>AF0475L5</b>	51.019"	37.632"	36.456"	55 Gallon (400 lbs)
(for -1 model)				
	"A"	"B"	"C"	"Container Suitability"
<b>AF0475L4</b>	44.974"	29.507"	28.331"	16 Gallon (120 lbs)
<b>AF0475L5</b>	53.104"	37.632"	36.456"	55 Gallon (400 lbs)

## PARTS LIST / LOWER PUMP END

Item	Description (size in inches)	Qty	Part No.	[Mtl]
1	<b>Connecting Rod</b>			
	models AF0475L43PBL1-X	(1)	97358-2	[C]
	models AF0475L53PBL1-X	(1)	97358-1	[C]
2	<b>Extension Tube</b>			
	models AF0475L43PBL1-X	(1)	97354-2	[C]
	models AF0475L53PBL1-X	(1)	97354-1	[C]
	<b>Piston &amp; Tube Ass'y (includes 3-7)</b>	(1)	97365	
3	<b>Plunger</b>	(1)		[C]
4	<b>Lower Tube</b>	(1)		[C]
5	<b>Ball Stop</b>	(1)		[C]
6	<b>Ball (9/32" dia.)</b>	(1)		[C]
7	<b>Primer Rod</b>	(1)		[C]
8	<b>Primer Tube</b>	(1)	97357	[C]
9	<b>Primer</b>	(1)	97373	[C]
✓10	<b>Retaining Ring</b>	(1)	94397	[C]
✓11	<b>Guide Washer</b>	(1)	97369	[Co]
12	<b>Spacer Sleeve</b>	(1)	97372	[C]
✓13	<b>Gasket</b>	(1)	97375	[Co]
14	<b>Valve Seat</b>	(1)	97362	[C]
✓15	<b>Truarc Ring</b>	(1)	76243-1	[C]
✓16	<b>"U" Cup (1/8" x 13/16" o.d.)</b>	(1)	Y186-54	[B]
✓17	<b>Guide</b>	(1)	95132	[T]
18	<b>Valve Body</b>	(1)	97363	[SH]
✓19	<b>Gasket</b>	(1)	97460	[C]
✓	<b>Parts in Lower Repair Kit</b>		637512	

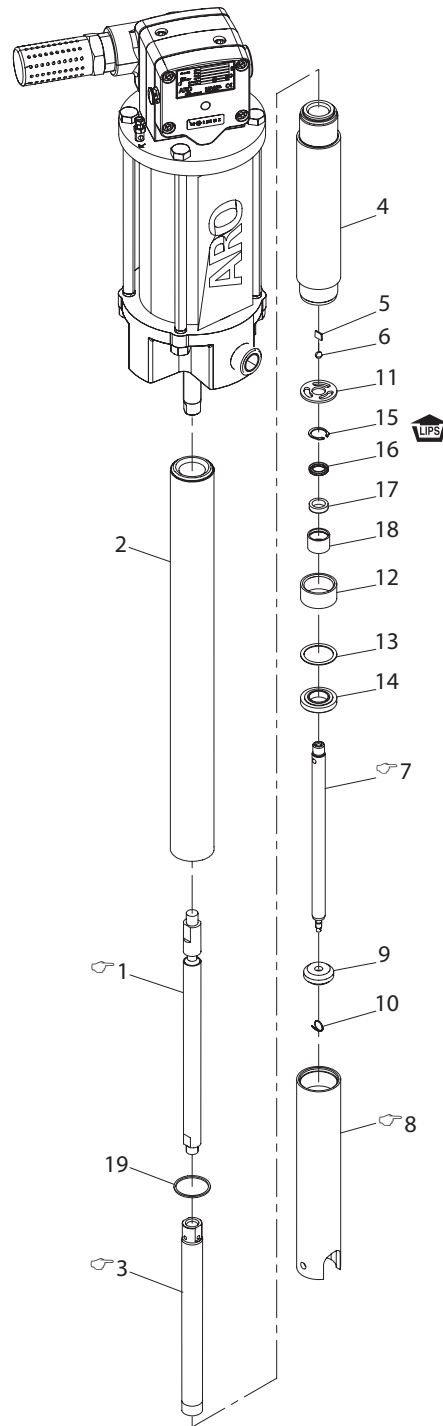

### OPERATING AND SAFETY PRECAUTIONS

**⚠ WARNING EXCESSIVE INLET PRESSURE.** Can cause explosion resulting in severe injury or death. Do not exceed maximum operating pressure of 7,500 psi (517 bar) at 100 psi (6.9 bar) inlet air pressure. Do not run pump without using a regulator to limit air supply pressure to the pump.

**⚠ WARNING EXCESSIVE MATERIAL PRESSURE.** Can cause equipment failure resulting in severe injury or property damage. Do not exceed the maximum material pressure of any component in the system.

$$\text{PUMP RATIO X INLET PRESSURE TO PUMP MOTOR} = \text{MAXIMUM PUMP FLUID PRESSURE}$$

Pump ratio is an expression of the relationship between the pump motor area and the lower pump end area. When 150 psi (10 bar) inlet pressure is supplied to the motor of a 4:1 ratio pump it will develop a maximum of 600 psi (41.4bar) fluid pressure (at no flow) - as the fluid control is opened, the flow rate will increase as the motor cycle rate increases to keep up with the demand.

**NOTICE** Thermal expansion can occur when the fluid in the material lines is exposed to elevated temperatures. Example: Material lines located in a non-insulated roof area can warm due to sunlight. Install a pressure relief valve in the pumping system.

#### Material Code

[B] = Nitrile  
 [C] = Carbon Steel  
 [Co] = Copper  
 [SH] = Hard Stainless Steel  
 [T] = PTFE  
 [U] = Polyurethane  
 [SS] = Stainless Steel

#### Torque Requirements

(1, 3 & 7) 50 - 60 ft lbs  
 (8) 340 - 360 ft lbs

### TROUBLESHOOTING

#### No material at outlet. (Pump continuously cycles).

- Empty material supply. Disconnect the air, replenish the material supply.
- Foreign matter is holding foot valve seats open in lower pump tube assembly. Remove lower pump tube assembly and clean valve seats.

#### Pump operates sluggishly, tends to stick when air is applied or control is opened.

- Air motor is dirty or lacks lubrication. Clean air motor.
- Insufficient air pressure or volume of air. Check air supply.

Figure 2

#### Air bypasses through exhaust port.

- Foreign matter is holding air valve open or lacks lubrication. Consult factory for nearest Service Center.

#### Motor stalls.

- Foreign matter in pump, hose, control valve or spray tip obstructing material flow. Check material supply hose and control valve or tip.
- Air not getting to pump. Check air supply.

## PUMP DISASSEMBLY

**NOTE: All threads are right hand. Disconnect air supply and relieve all system pressure prior to servicing.** Carefully remove the parts, inspect for damage, nicks or excessive wear and determine if any parts will need replacement.

1. Clamp (2) extension tube horizontally in a vise. Unthread from air motor base. Take care to support motor weight until the connecting rod is also disconnected.
2. Pull (1) connecting rod up until flats for 5/8" wrench are exposed.
3. Use 5/8" wrench flats on each rod to unthread (1) connecting rod from the air motor rod.
4. Clamp (4) lower tube horizontally in a vise. Use a rod or pipe to unthread and remove (8) primer tube. Allow primer (9) to pull (12) spacer sleeve, (13) gasket and (14) valve seat out of the (8) primer tube as it is being removed.
5. Remove (10) retainer ring and unthread (9) primer from (7) primer rod.
6. Remove (11-18) from (6) primer rod.
7. Remove (15) truarc ring, releasing (16) "U" cup. **NOTE:** Do not remove (17) guide unless replacement is necessary.
8. With (4) lower tube still clamped horizontally in a vise, unthread and remove (2) extension tube and (19) gasket.
9. Using a the 5/8" wrench flats on the (1) connecting rod and the 3/4" wrench flats on the plunger (3), unthread and remove the (1) connecting rod from the (3) plunger. **NOTE:** Do not damage the o.d. of (3) plunger in any way.
10. Using a 5/32" diameter rod in the cross hole of (9) primer rod and the 3/4" wrench flats on the plunger, unthread and remove (9) primer rod, releasing (6) ball and (5) ball stop.

## PUMP REASSEMBLY

**NOTE: Replace all soft parts with new ones included in the repair kit.** Refer to the illustration (Figure 2, page 2) for "U" cup seal direction.

1. Assemble (5) ball stop and (6) ball into (3) plunger, securing with (7) primer rod. **NOTE 1:** Torque (7) primer rod to 50-60 ft lbs (67.8-81.3 Nm). **NOTE 2:** Items 3-7 are not individually serviceable but must be replaced as an assembly (97365).
2. Thread (1) connecting rod to (3) plunger, using 5/8" and 3/4" wrench flats respectively. **NOTE:** Tighten (1) connecting rod to 50-60 ft lbs (67.8-81.3 Nm).
3. Assemble (17) guide and (16) "U" cup into (18) valve body, securing with (15) truarc ring. **NOTE:** Assemble chamfered corner of (17) guide into (18) valve body first.
4. Assemble (11) guide washer and (15-18) foot valve assembly onto (7) primer rod.
5. Assemble (12) spacer sleeve, (13) gasket, and (14) valve seat into (8) primer tube.
6. Thread (8) primer tube to (4) lower tube and hand tighten.
7. Push piston assembly down as far as possible and thread (9) primer onto (7) primer rod, securing with (10) retainer ring.
8. Assemble (19) gasket and (2) extension tube to (4) lower tube and hand tighten.
9. Ensure (91415) packings (3x), (90142) washer, (90143) spring, and (90140) washer are secure inside of (AF0465) air motor base.
10. Pull (1) connecting rod up until flats for 5/8" wrench are exposed.
11. Using the 5/8" wrench flats on (1) connecting rod and the air motor rod, thread and tighten. **NOTE:** Torque (1) connecting rod to 50-60 ft lbs (67.8-81.3 Nm).
12. Assemble (2) extension tube to air motor base. Clamp base horizontally in vise and tighten (8) primer tube to 340-360 ft lbs (461.0-488.1 Nm) in order to tighten tubing components simultaneously.

## DIMENSIONS

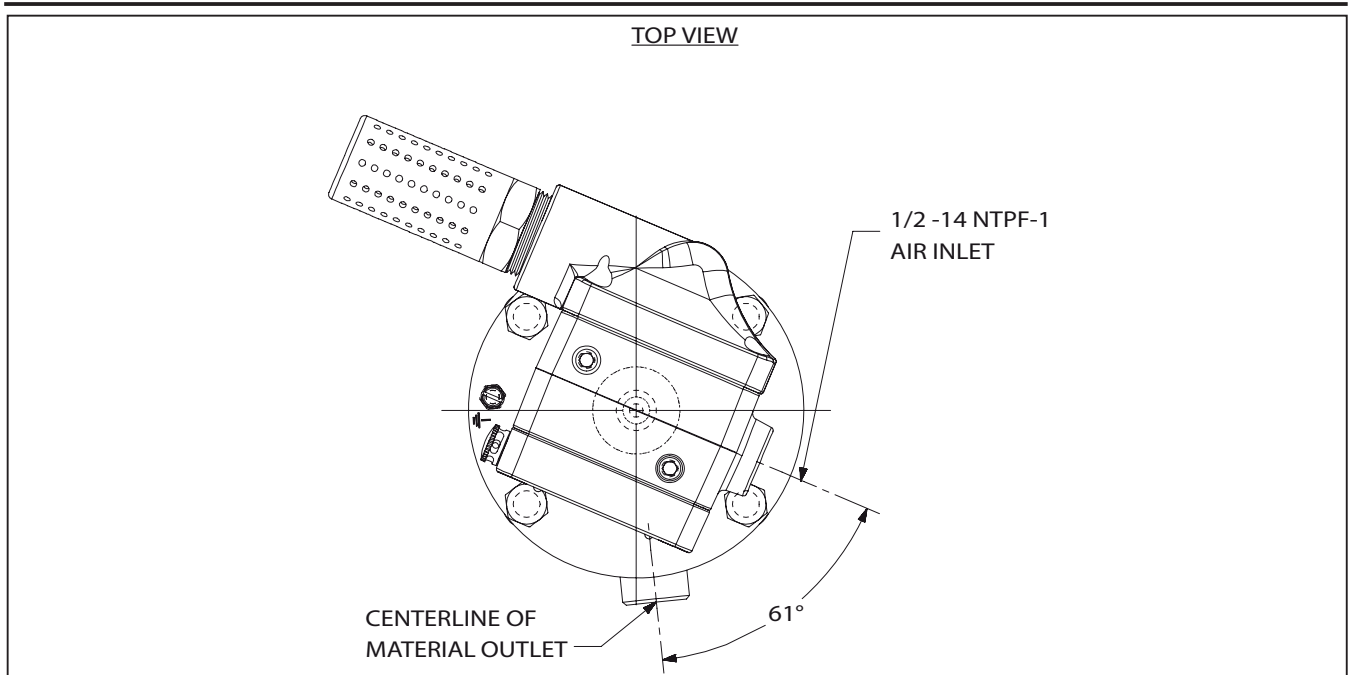

# PERFORMANCE CURVES

## NLGI #1 Grease at Room Temperature

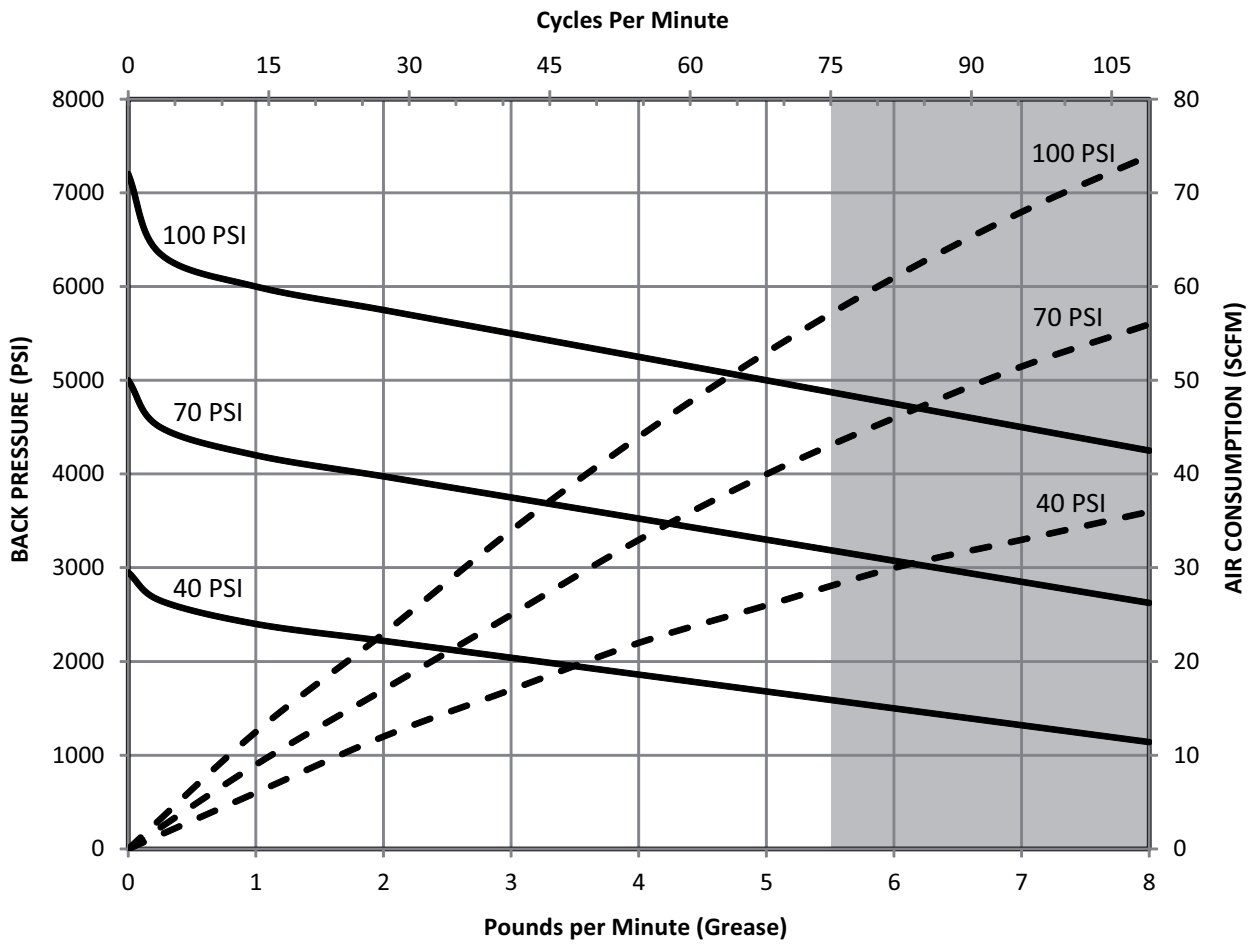

NOTE: NON SHADED AREA OF THE GRAPH REPRESENTS RECOMMENDED OPERATING RANGE FOR CONTINUOUS DUTY